

THE 'NATURE' OF CRAFT



CONTENCE

1-2 Contence and Statement

3-4 Project map

5-6 Flow-state: animation development

6-7 Flow-state: making

8-11 Flow-state: vessels

12-14 The Pod: working with willow

15-16 The Pod: plant, Cut, make

17-20 The Pod: final piece

21-22 The Botanical Press: initial idea

23-24 The Botanical Press: making

25-28 The Botanical Press: in action

STATEMENT

My experience of 'lockdown' cemented my interest in the process of making and it's beneficial affect on both mental, physical and emotional well-being. Being fortunate in living in the countryside I was able to make use of the natural materials around me.

The act of craft combined with the support of my natural surroundings helped me to navigate the uncertainties of this time.

My research culminates in three projects;

1. **Flow-state Vessels** are an investigation into the personal impact of the act of making, in particular the meditative hyper-focus that a maker can experience.

2. **The Pod** is a sculptural piece representing the rhythms of both craft and nature. It appeals to the senses, visual, kinasthetic, aromatic and auditory which parallels experiences of nature.

3. **The Botanical Press** is a product designed to connect people with their natural environment. It is a flower press that facilitates the pressing of plants into 3D forms. It is an accessible introduction to craft encouraging growing and collecting plants thereby connecting people with the rhythms of nature.



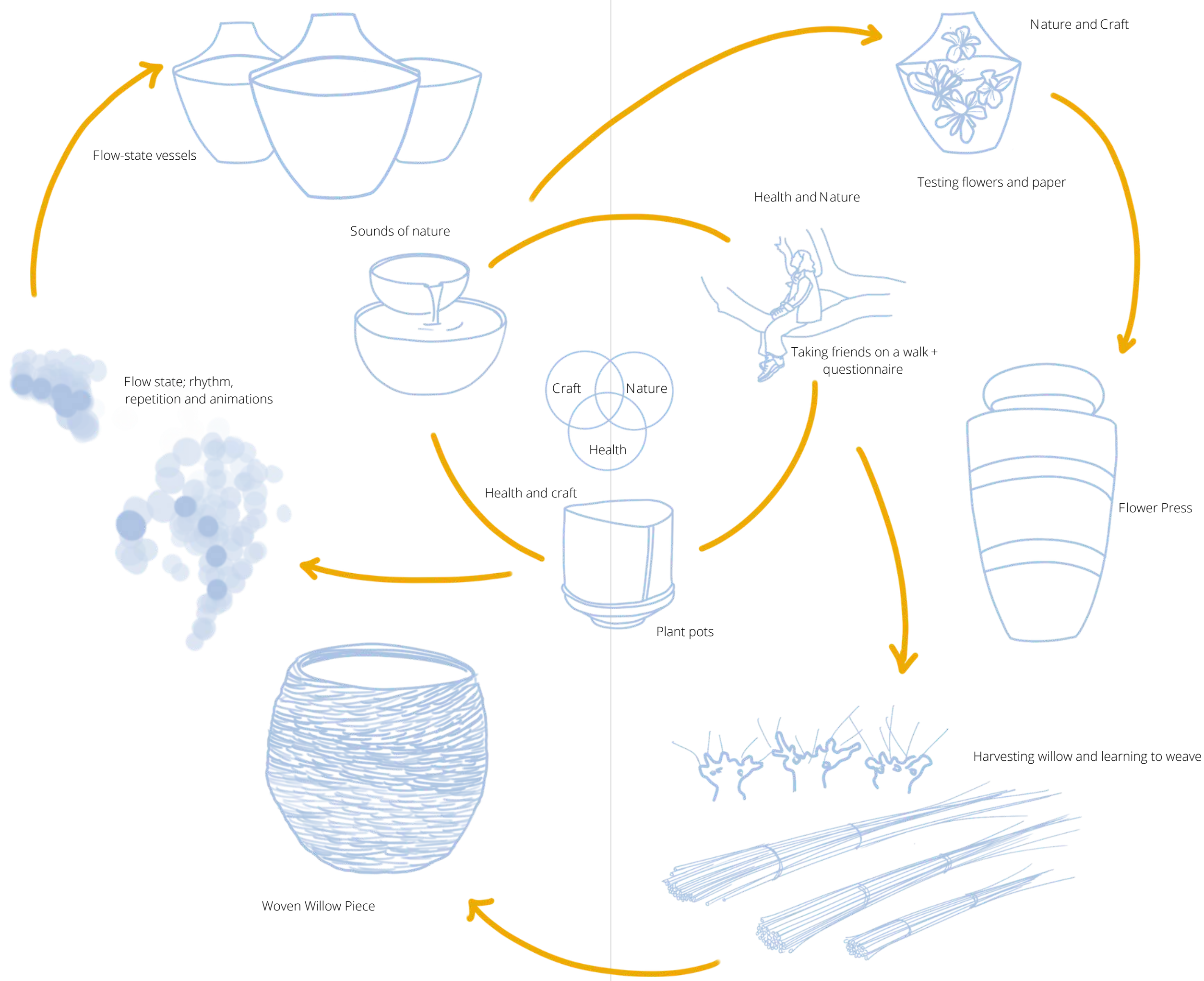

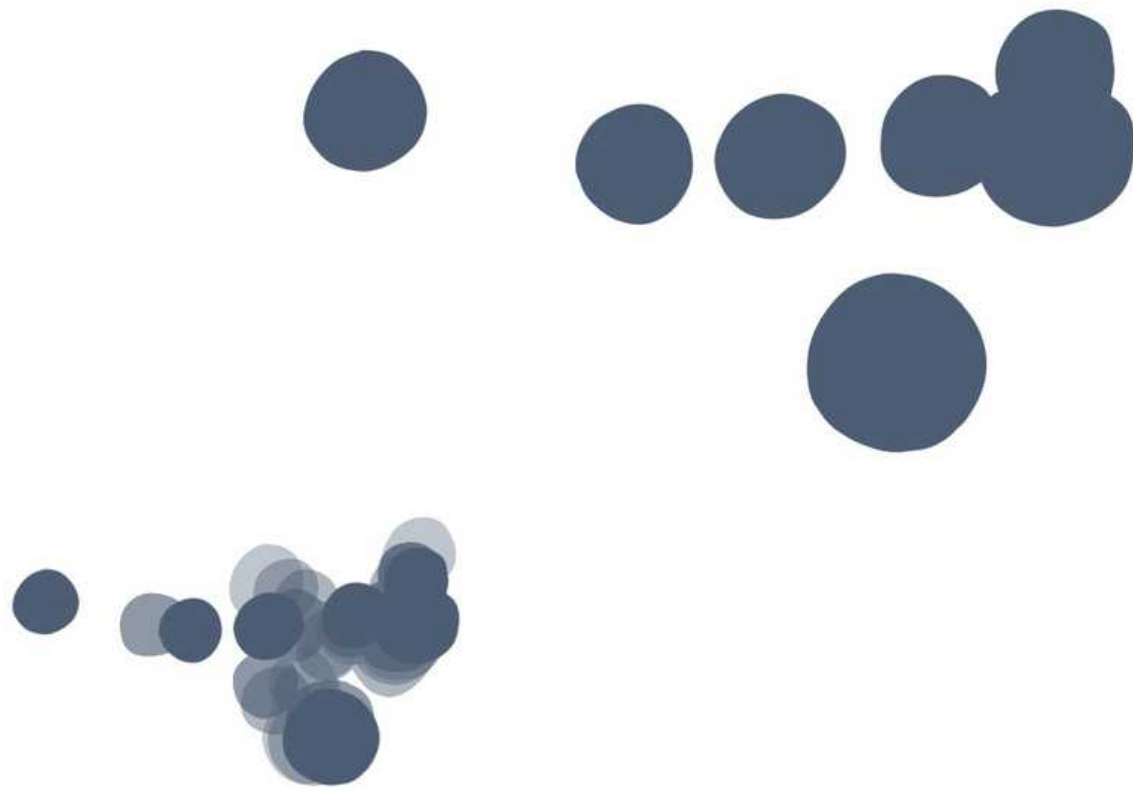

Above - Animation still and layered frames of stills

In order to understand the effect that the act of craft has on the maker I created animations taken from videos of myself making with various materials including metal, ceramics and polymers. Through videoing working with these materials I discovered that it is the rhythm and repetition of the making process that has a hypnotic and calming affect on the maker. These are the components of the resulting 'flow-state' in the mind and body of the maker.

In order to realise this in 3D form I simplified these components by abstracting the movements and rhythms of the crocheting animation by distilling it into layered frames. In order to further simplify the resulting images I drew outlines around them and used these to form templates which I then used to build a multi-faceted vessel.

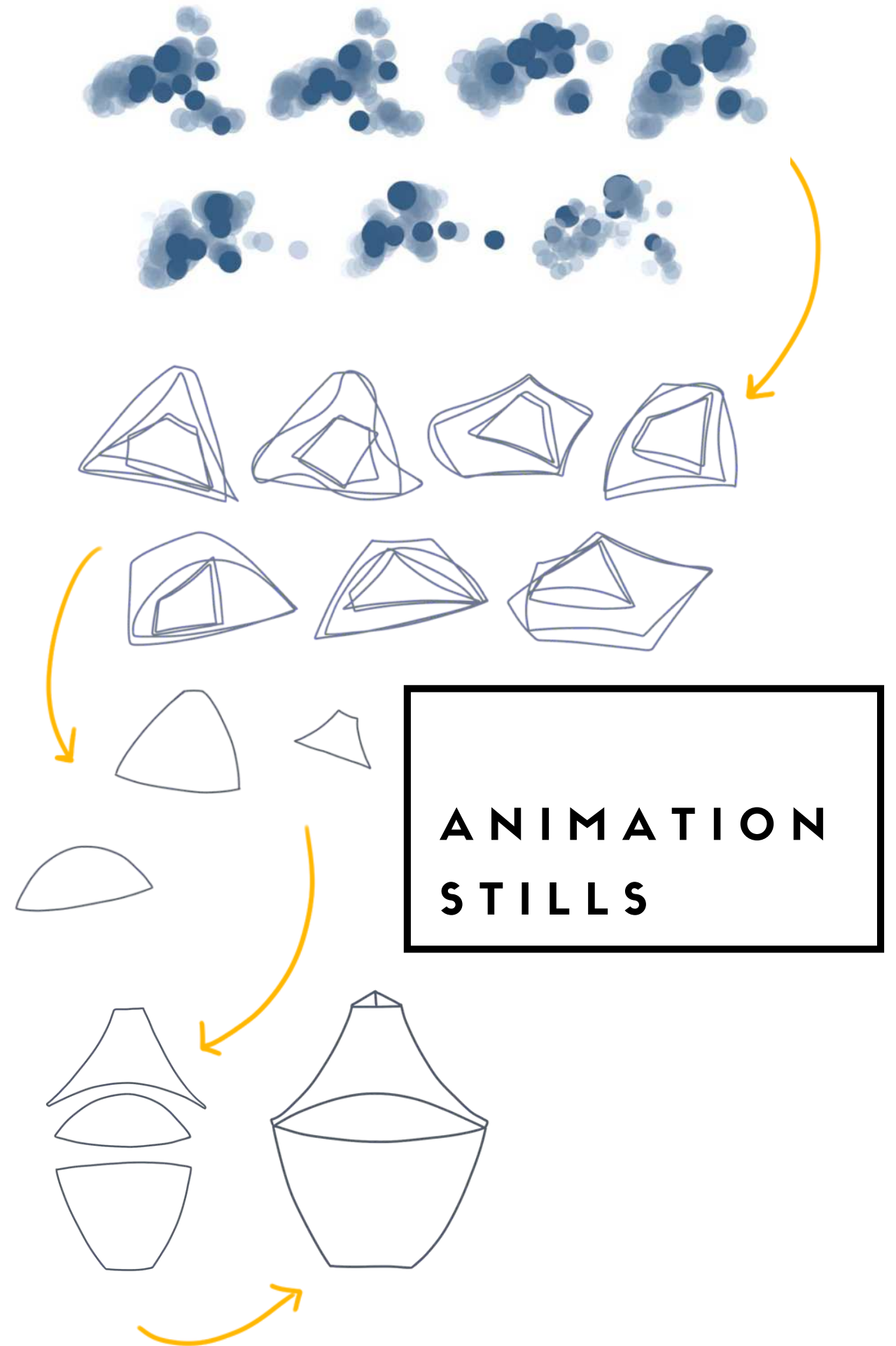

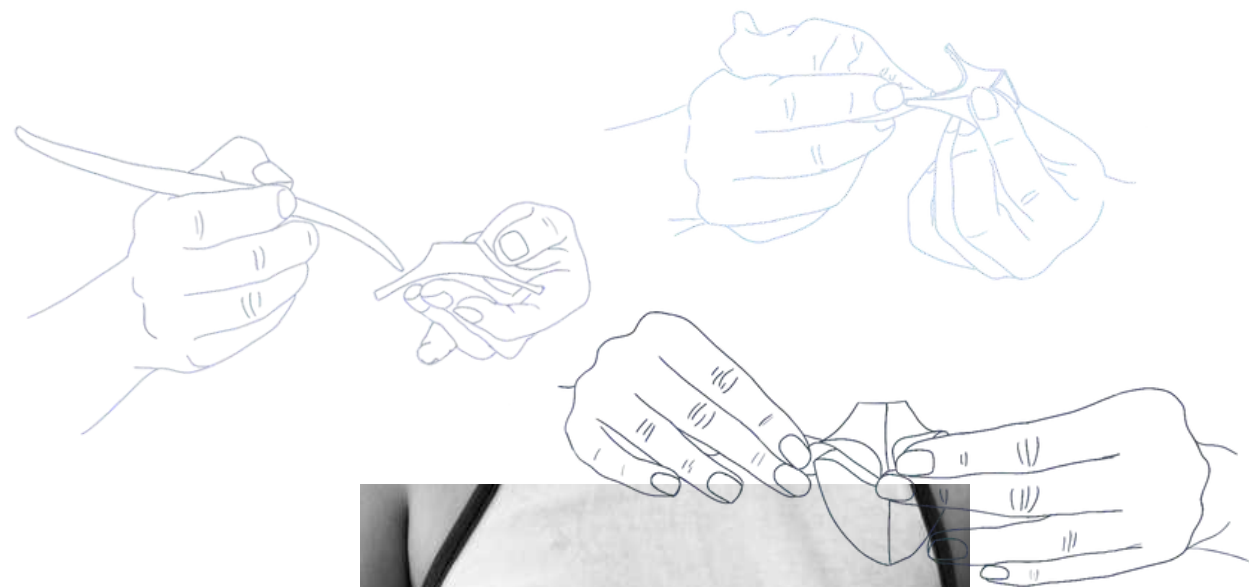

To further my understanding of my own experience of flow state I began to make variations of this vessel over a 4-week period. I documented the date, size and duration of making each piece along with the weather, my mood and whether or not I experienced 'flow-state' whilst making. Although my skills developed these factors contributed to the finesse of the resulting pieces. I was interested to notice that the natural environment ie the weather not only had an impact on my mood, it also affected the clay. On warm days it dried out the clay so I had to adjust the process accordingly.



**FLOW
STATE
VESSELS**



In continuously repeating the making process and by keeping the log these multiples represent my own journey to understand flow-state.



date: 11.4.22
size/ duration: 70mm 2h
mindset: frustration
weather: overcast
to note: template wrong so adjusted



date:15.4.22
size/ duration: 50mm 1.5h
mindset: flow
weather: sunshine
to note: door open + birdsong

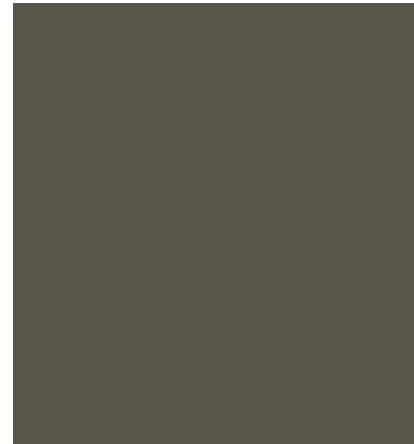

date: 13.4.22
size/ duration: 40mm 2h
mindset: flow
weather: cloudy
to note:



date: 19.4.22
size/ duration: 80mm 54m
mindset: flow
weather: sunshine
to note: listening to material matters podcast



date:19.4.22
size/ duration: 40mm 1h
mindset: flow
weather: sunshine
to note: doors open





THE POD



The Pod is a visual representation of the rhythm and repetition in craft and the cyclical nature of making with a natural material. Working with willow is a circular process. The seasonal rhythm of planting, harvesting and drying, is followed by soaking, then finally the weaving begins. Here the weaving itself is also a circular and rhythmic motion.



PLANT,



CUT,



MAKE,

Each year the maker repeats this process. However, just as the weave builds upon itself in a spiral form so does the weaver's skill and experience; no two year's work will be the same because the maker is changed by their experience just as the willow plant is transformed. This parallel demonstrates the potentially infinite capacity of both nature and the maker to evolve.



PLANT,

CUT,

MAKE,



FINAL PIECE



Like a seed pod 'The Pod' is a container for the creative potential of the maker whether they are a weaver, a ceramicist or any other maker. The final weave is a collaboration between maker and nature.

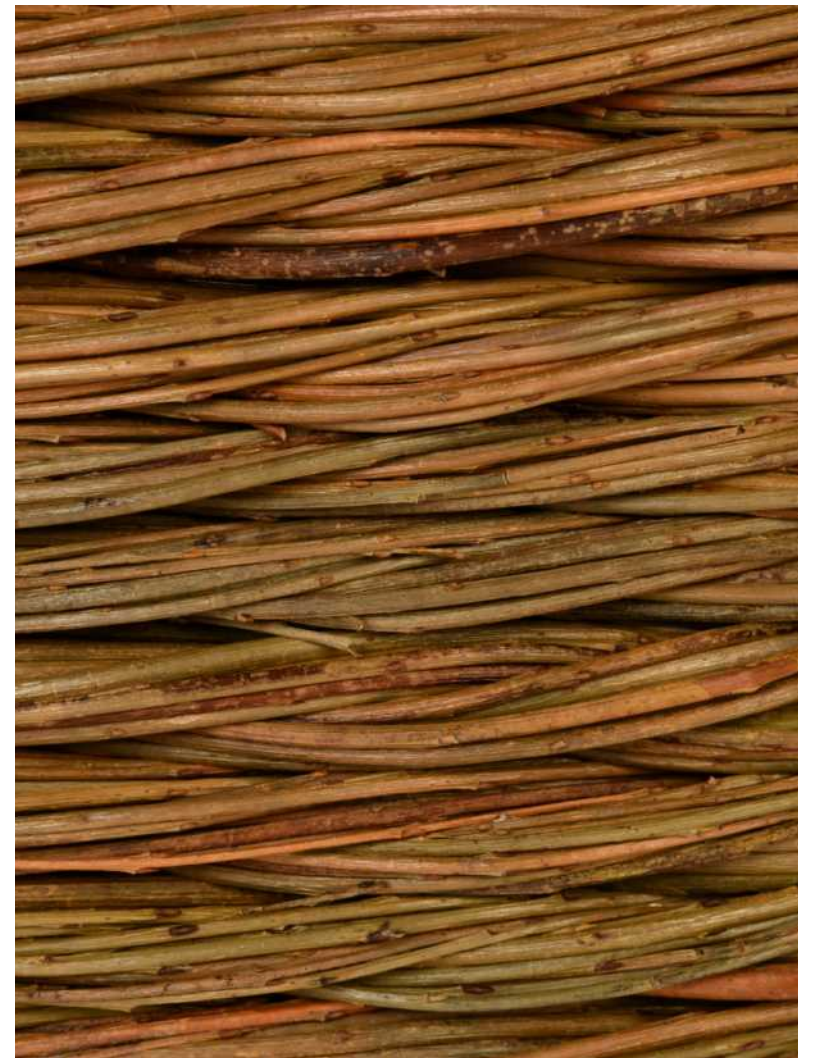



The Botanical Press - is a prototype product created for anyone who wants to immerse themselves in nature and create something both sustainable and beautiful. It encourages the cultivation and preservation of plants and flowers, and creates mementoes of the experience and hard work. This product is a culmination of my research which enables others to share in the experience of the act of making within nature.

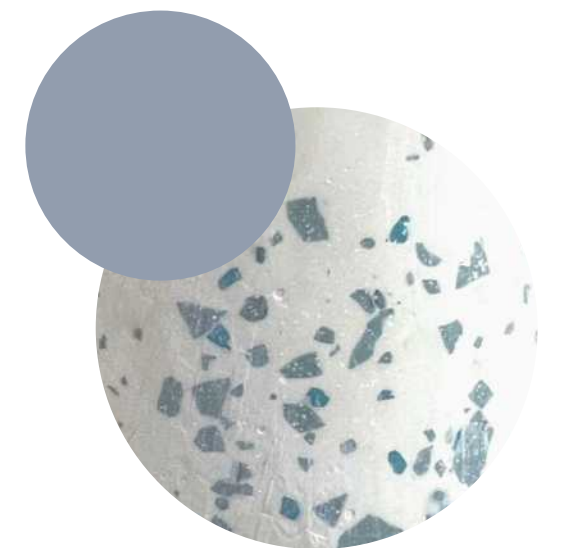
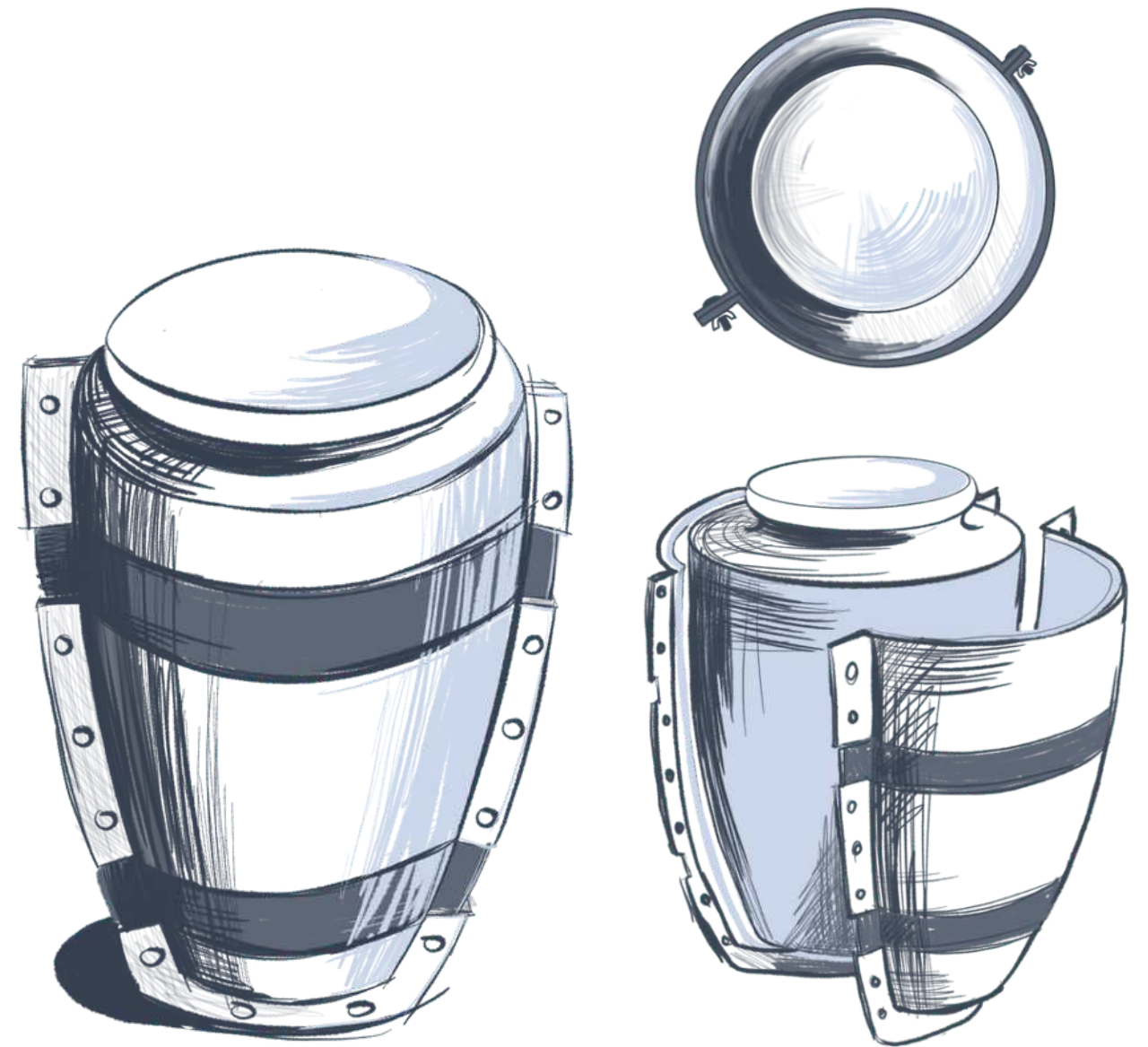

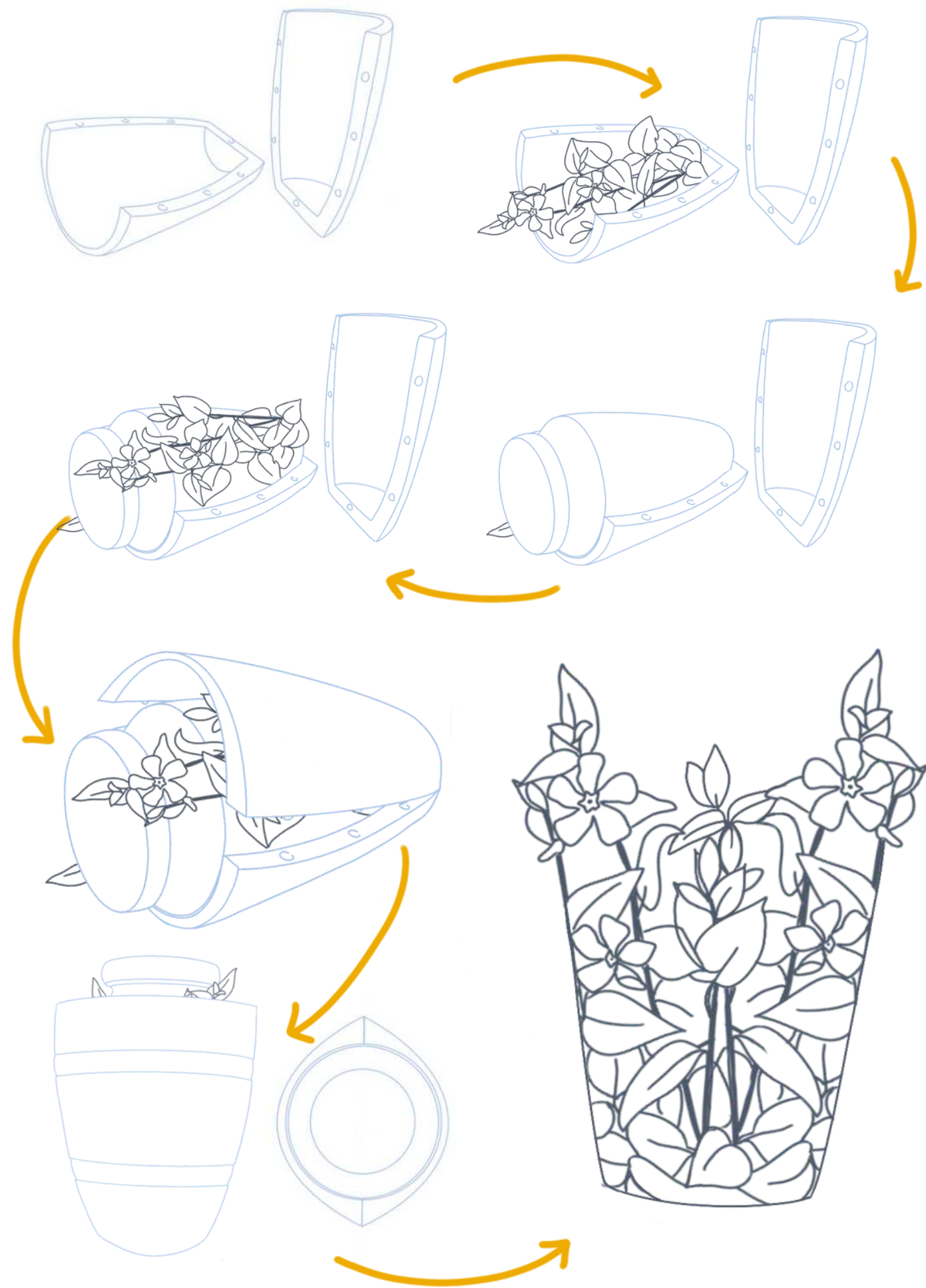

THE BOTANICAL PRESS





Whether someone has their own garden or a window box they can grow their own plants and invest time and effort in their natural surroundings and continuously enjoy the rhythm of nature's seasons.



Result of press.

